

# Problem info

Problem type: Magnetostatics

Geometry model class: Plane-Parallel

Problem database file names:

- Problem: *Magnet.pbm*
- Geometry: *Magnet.mod*
- Material Data: *Magnet.dms*
- Material Data 2 (library): *none*
- Electric circuit: *none*

Results taken from other problems:

- *none*

# Geometry model

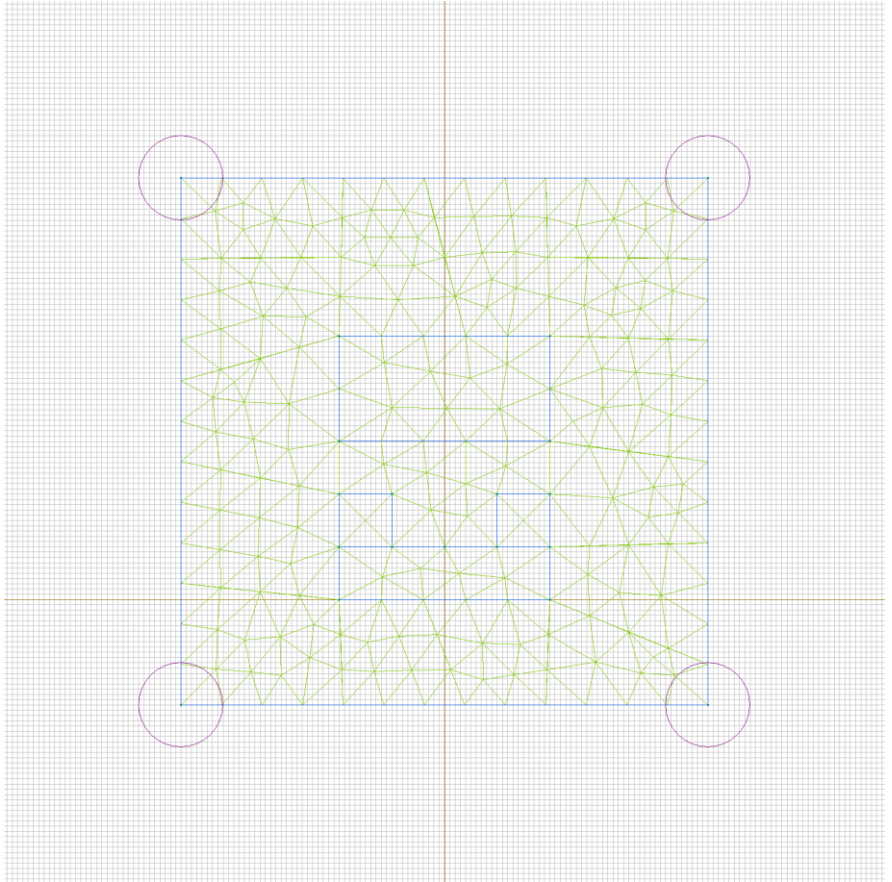

Table 1. Geometry model statistics

	With Label	Total
Blocks	4	5
Edges	1	21
Vertices	0	19

Number of nodes: 227.

# Labelled objects

There are following labelled objects in the geometry model (Material Data file could contain more labels, but only those labels that assigned to geometric objects are listed)

Blocks:

- [Air](#)
- [Steel](#)
- [Magnet+](#)
- [Magnet-](#)
- 

Edges:

- [Zero](#)
- 

Vertices:

Detailed information about each label is listed below.

Labelled objects: block "Air"

There are (1) objects with this label

Relative magnetic permeability:  $\mu_x=1$ ,  $\mu_y=1$

Current density:  $j=0$  [A/m<sup>2</sup>]

Conductor's connection: in parallel

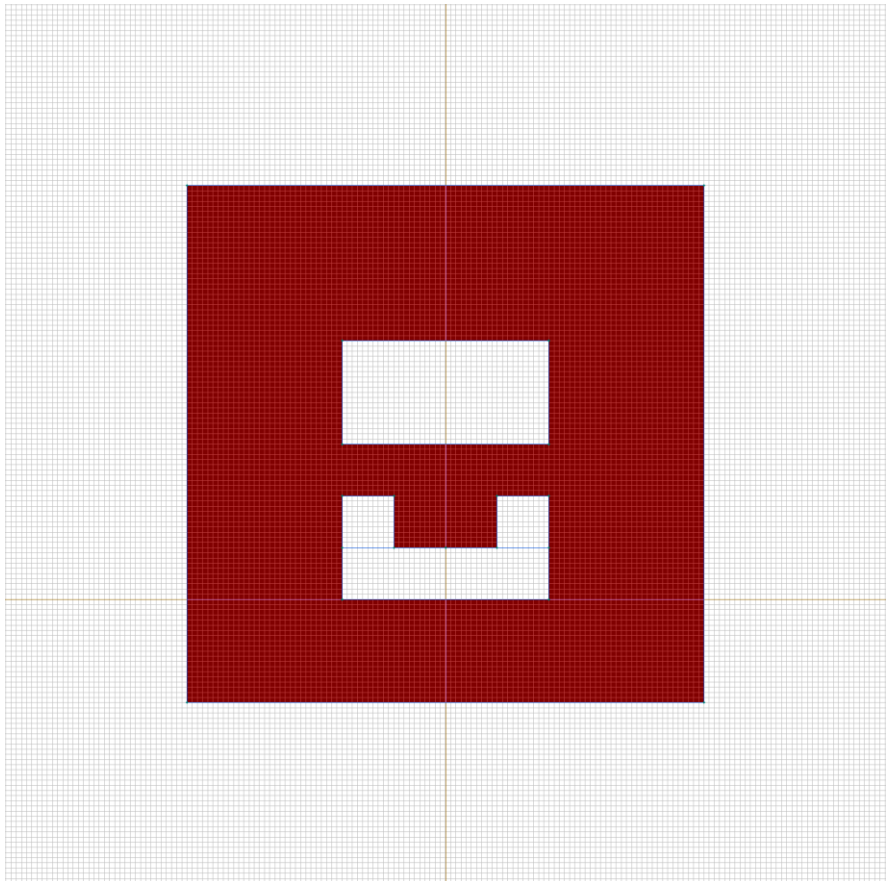

Labelled objects: block "Steel"

There are (2) objects with this label

Relative magnetic permeability:  $\mu_x=1000$ ,  $\mu_y=1000$

Current density:  $j=0$  [A/m<sup>2</sup>]

Conductor's connection: in parallel

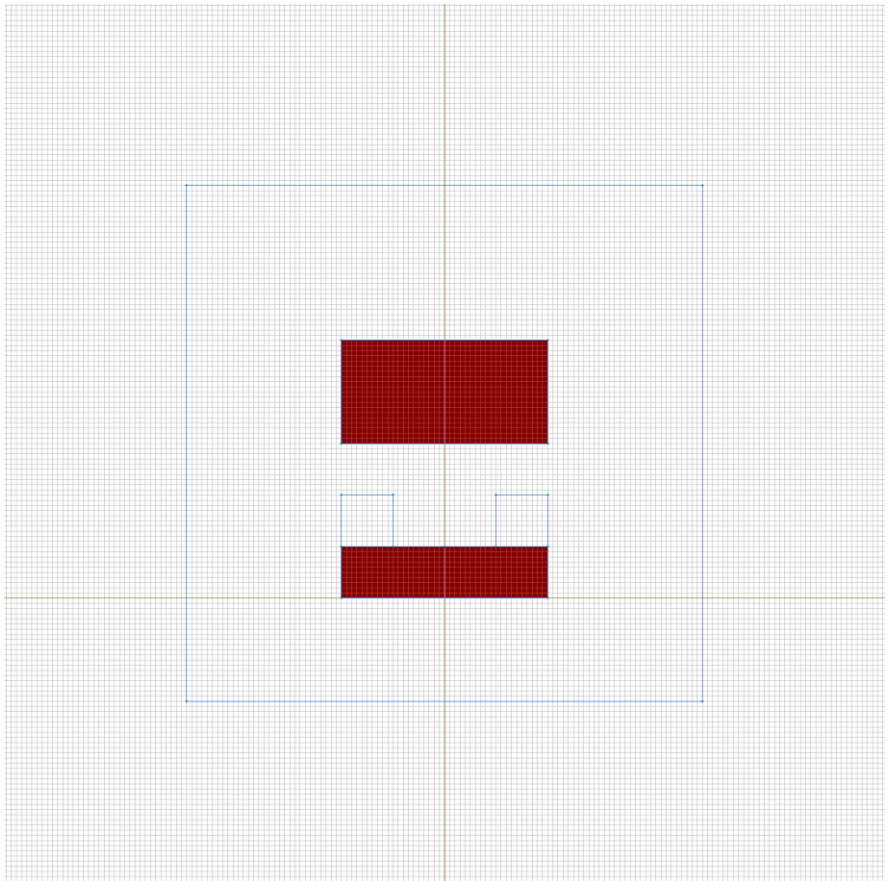

Labelled objects: block "Magnet+"

There are (1) objects with this label

Relative magnetic permeability:  $\mu_x=1$ ,  $\mu_y=1$

Coercive force:  $H_c=500000$  [A], direction: 90 [deg]

Current density:  $j=0$  [A/m<sup>2</sup>]

Conductor's connection: in parallel

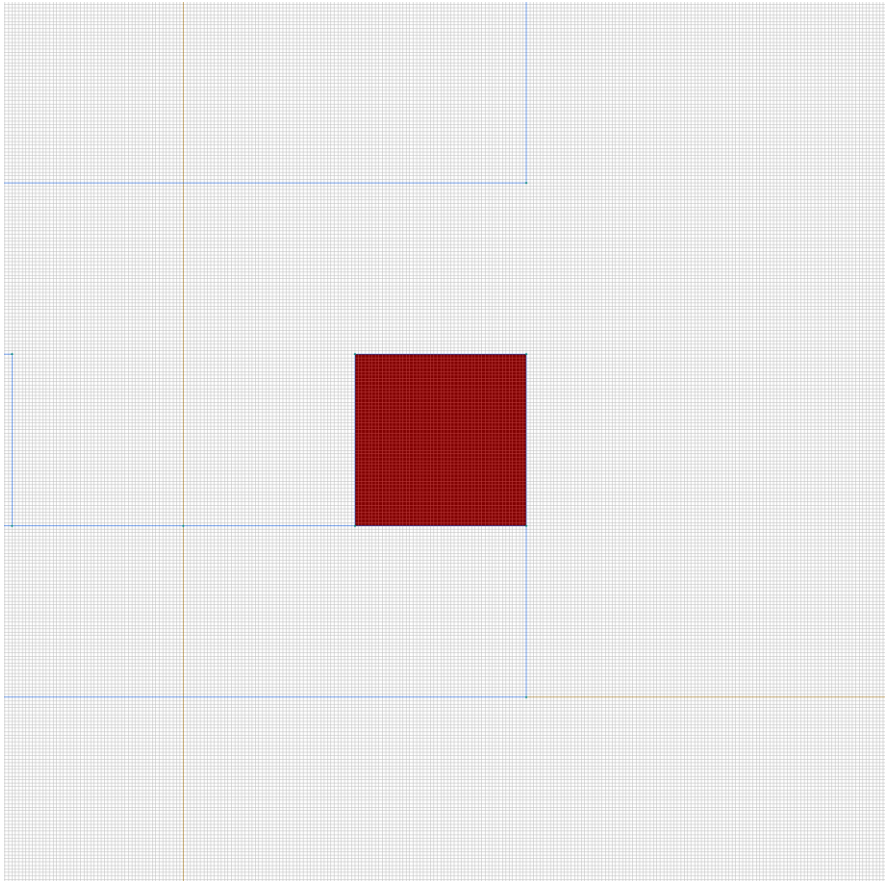

Labelled objects: block "Magnet-"

There are (1) objects with this label

Relative magnetic permeability:  $\mu_x=1$ ,  $\mu_y=1$

Coercive force:  $H_c=500000$  [A], direction:  $-90$  [deg]

Current density:  $j=0$  [A/m<sup>2</sup>]

Conductor's connection: in parallel

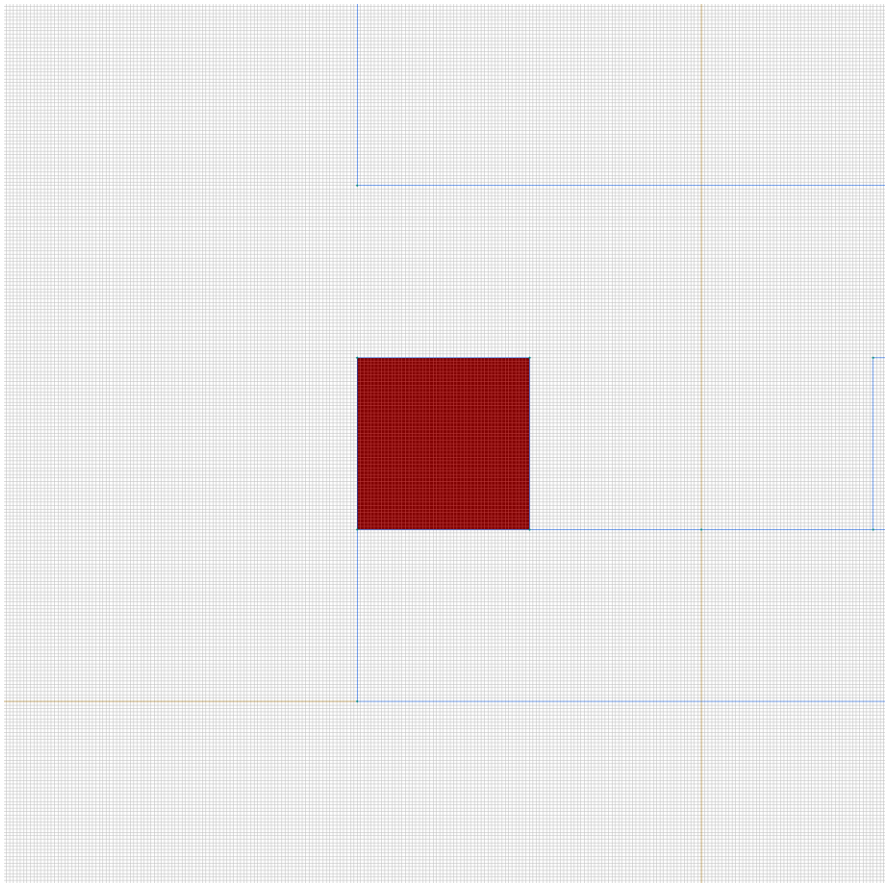



Labelled objects: edge "Zero"

There are (4) objects with this label

Magnetic potential:  $A=0$  [Wb/m]

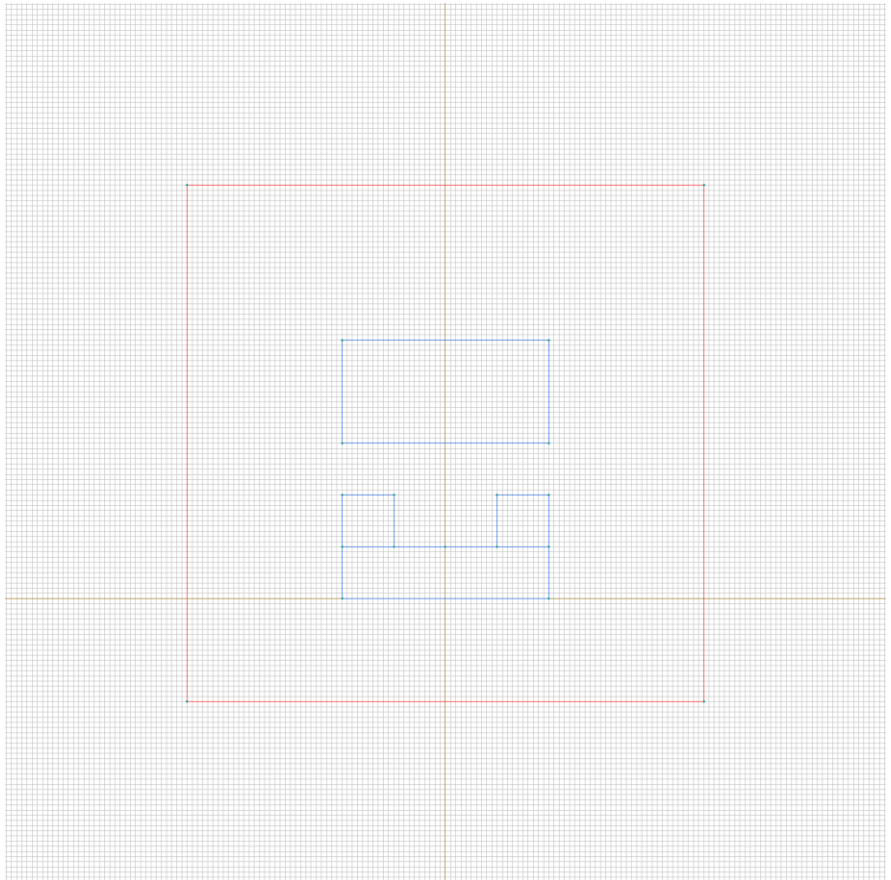



# Results

Field lines

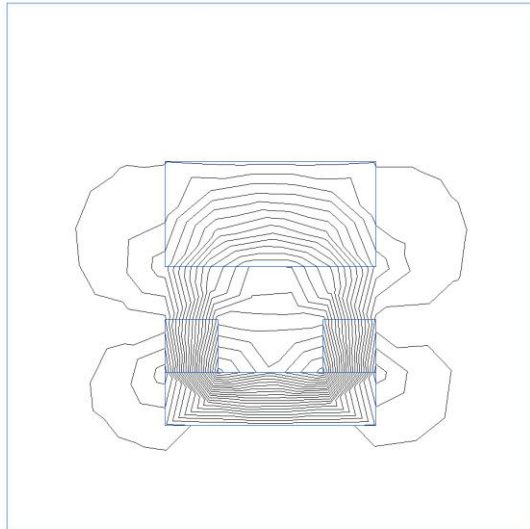

# Results

Color map of Strength  $|H|$  [A/m]

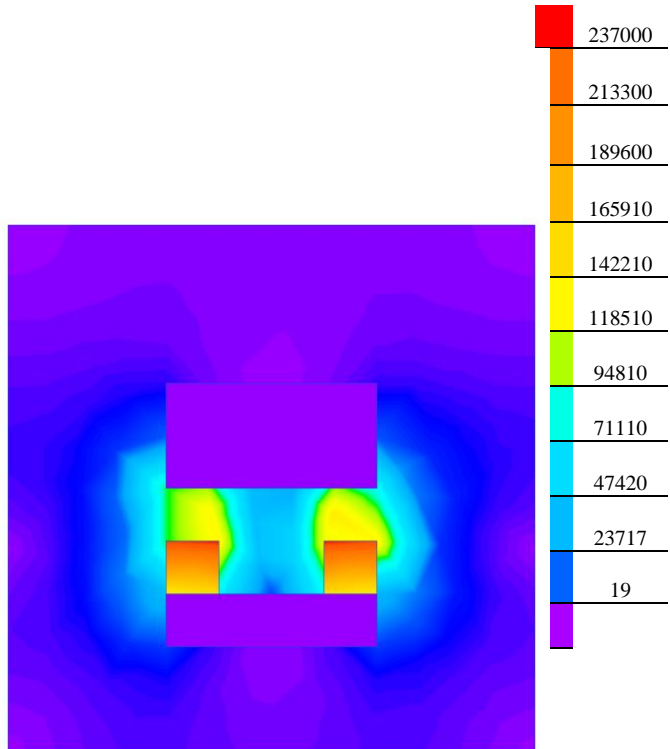

# Nonlinear dependencies

No non-linear dependencies are used in this problem data